

CAUTION! Installation and connection should only be carried out by a qualified person and in accordance with national wiring regulations.

- Before commencing any work on the electrical connections, you must first disconnect the programmer from the mains. None of the 230V connections must be live until the installation has been completed and the housing is closed. Only qualified electricians or authorised service staff are permitted to open the programmer. Disconnect from mains supply in the event of any damage to any buttons.
- There are parts that carry mains voltage behind the cover. The programmer must not be left unsupervised when open. (Prevent non specialists and especially children from gaining access to it.)
- If the programmer is used in a way not specified by the manufacturer, its safety may be impaired.
- Prior to setting the timeswitch, it is necessary to complete all required settings described in this section.
- Never remove this product from the electrical baseplate. Do not use sharp tools to push any button.



Important: Keep this document

This 2 zone programmer is designed to provide ON/OFF control for one hot water and one heating zone.



This programmer can be mounted in the following ways: 1. Directly wall mounted 2. Mounted to a recessed conduit box

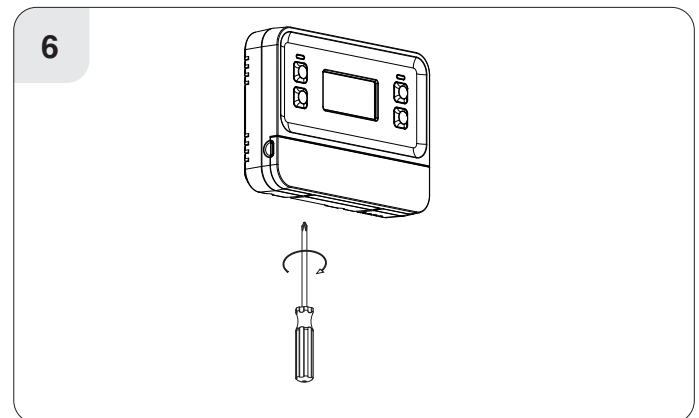
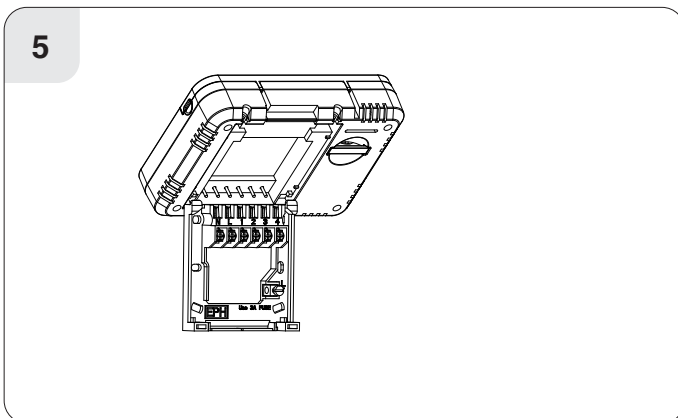
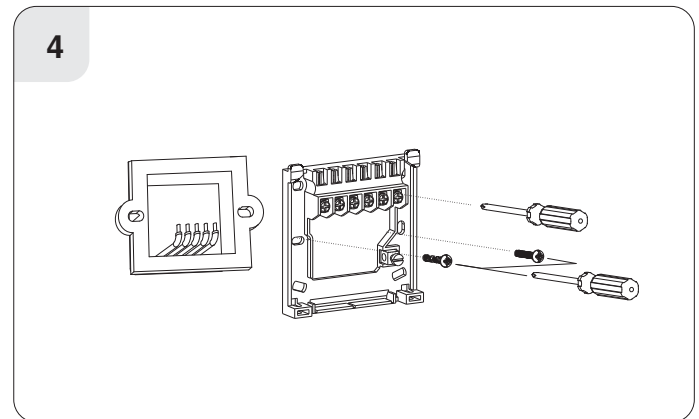
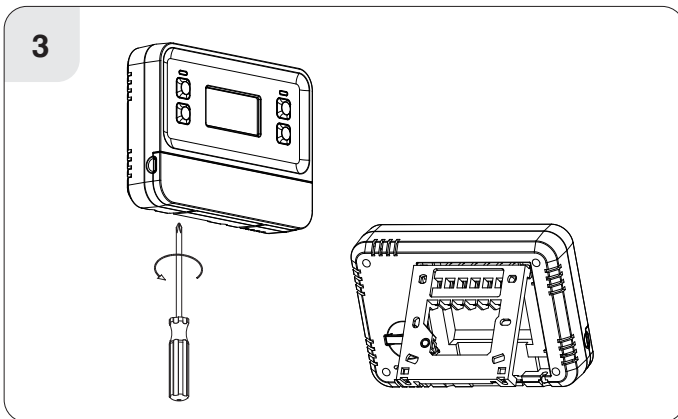
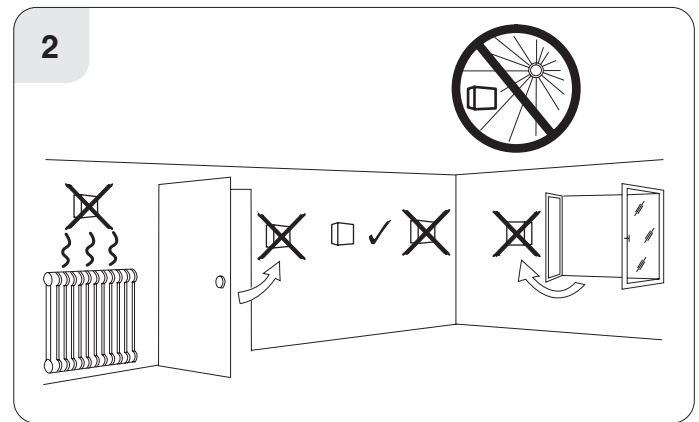
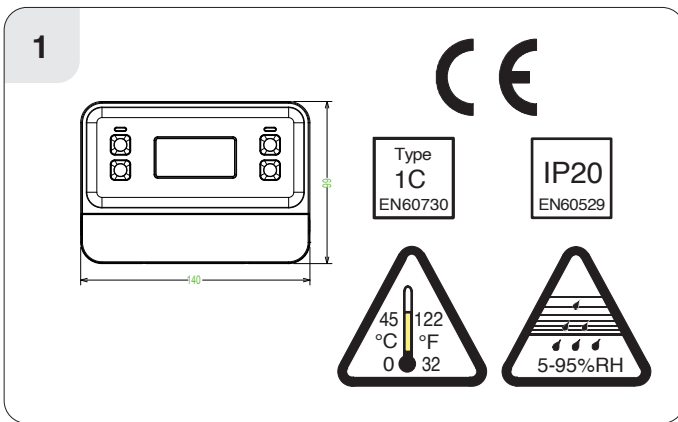



Contents

1. Factory default settings
2. Specifications & wiring

1. Factory default settings

Contacts:	230 Volt contacts
Program:	5/2D
Backlight:	On
Keypad:	Unlocked
Clock type:	24 Hr Clock
Day-Light Saving	

2. Specifications & wiring

Power Supply:	200 - 240 Vac, 50-60 Hz, 8 VA
Ambient Temp:	0~45°C
Relative Humidity Range:	5-95 % RH
Contact Rating:	250 Vac 3(1)A
Program Memory backup:	3 months
Battery:	3Vdc CR 2032
Backlight:	Blue
IP rating:	IP20
Backplate:	British System Standard
Rated Impulse Voltage:	Resistance to voltage surge 2500V as per EN 60730
Pollution Degree:	Pollution Degree 2
Automatic Action:	Type 1.C
Software:	Class A

