

## BUF: 3--way valve with male thread, PN16

### Features

- Control valve for continuous control of cold water, and hot water in closed networks.
- Water quality as per VDI 2035.
- In combination with valve actuators AVM 105/115 (S) and AVF 124/125S as control unit.
- Characteristic can be set with SUT (SAUTER Universal Technology) valve actuators to linear, equal-percentage or quadratic.
- Valve body and seat made of grey cast iron.
- Stainless-steel spindle and plug, with EPDM soft seat.
- Stuffing box made of brass with EPDM O-ring seal.
- Delivery of the valves with fittings of malleable cast iron and seal.
- Valve passage A–AB is closed when the spindle is moved out.
- Not suitable for drinking water or potentially explosive atmospheres.



Y07545

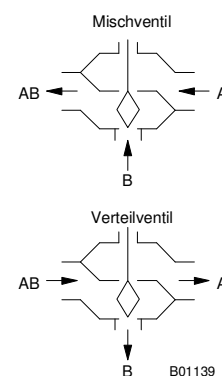

B01139

Type	Nominal Diameter DN	Connection	$k_{VS}$ -Value m <sup>3</sup> /h	Weight kg
BUF015F230	15	G 1B	1	1,35
BUF015F220	15	G 1B	1,6	1,35
BUF015F210	15	G 1B	2,5	1,35
BUF015F200	15	G 1B	4	1,35
BUF020F200	20	G 1¼B	6,3	1,75
BUF025F200	25	G 1½B	10	2,15
BUF032F200	32	G 2B	16	3,8
BUF040F200	40	G 2¼B	25	4,4

Operating temperature <sup>1)</sup>	+2...150 °C	Leakage rate	< 0,0005% of $k_{VS}$ -Wert
Operating pressure	bis 120 °C 16 bar	By pass	< 0,0005% of $k_{VS}$ -Wert
	bis 130 °C 13 bar	Nominal stroke	5,5 mm
Valve characteristic	linear		
By pass	linear		
Control ratio	50:1 (typical)	Dimension drawing	M07424

### Accessories

**0372240 001\*** Manual adjustment for valves VUN/BUN und VUF/BUF; MV 505813

**0372249 001** Temperature adapter (>100 °C up to max. 130 °C) for AVM, DN 15...50, MV 505932

**0372249 002** Temperature adapter (>130 °C up to max. 150 °C) for AVM, DN 15...50, MV 505932

\*) Dimension drawing or wiring diagram available under the same number

1) Use adaptor (accessory) at temperatures above 100 °C

Warranty	The technical data and pressure differences indicated here are applicable only in combination with SAUTER valve actuators. The warranty does not apply if used with valve actuators from other manufacturers.
----------	---

## Combination BUF with electrical drive

Drive	250 N pushing force		
Type:	AVM 105 F . . .	AVM 105S F . . .	
Running time:	30 s / 120 s	35 s / 60 s / 120 s	
Input::	2pt / 3pt	0...10 V or 2pt or 3pt	
Valve	As mixing valve		
	$\Delta p_{\max}$	$\Delta p_s$	close/off pressure
BUF015F230...F210	4	–	10
BUF015F200	4	–	8
BUF020F200	4	–	5,5
BUF025F200	3,5	–	3,5
BUF032F200	2,2	–	2,2
BUF040F200	1,3	–	1,3

Drive	500 N pushing force		
Type:	AVM115 F . . .	AVM115SF . . .	
Running time:	120 s	60 s / 120 s	
Input::	2pt / 3pt	0...10 V or 2pt or 3pt	
Valve	As mixing valve		
	$\Delta p_{\max}$	$\Delta p_s$	close/off pressure
BUF015F230...F210	4	–	16
BUF015F200	4	–	16
BUF020F200	4	–	13
BUF025F200	4	–	8
BUF032F200	4	–	5
BUF040F200	3	–	3

Drive	500 N pushing force					
Type:	AVF124 F . . .		AVF125SF . . .			
Running time:	60 s / 120 s		60 s / 120 s			
Input:	3pt		0...10 V or 2pt or 3pt			
Federrückzug:	18 ± 10 s		18 ± 10 s			
Valve	As mixing valve			As distribution valve		
	$\Delta p_{\max}$	$\Delta p_s$	close/off pressure	$\Delta p_{\max}$	$\Delta p_s$	close/off pressure
BUF015F2xx	4	16	16	3	16	16
BUF020F200	4	16	16	3	16	16
BUF025F200	4	8	8	2,8	8	8
BUF032F200	4	5	5	2,1	5	5
BUF040F200	3	3	3	1,4	3	3

Valve: Variant F, for technical data and accessories see Valve Type Table

Drive: Variant F, for technical data, accessories and installation position see section 51

Example: BUF015F210 / AVM115SF132

$\Delta p_{\max}$ [bar] = Maximum permitted pressure difference over the valve at which the drive can still reliably open and close the valve, taking account of  $\Delta p_v$ .

$\Delta p_s$  [bar] = Maximum permitted pressure difference over the valve in case of a fault (pipe break downstream of the valve) at which the drive can close the valve reliably with "fast" performance of the stroke.

close/off pressure = Maximum possible pressure difference over the valve in control mode, at which the drive can still open and close the valve. A reduced lifetime must be expected with this mode. Cavitation, erosion and pressure surges can damage the valve. The values are only valid for the assembled combination valve fitted on the drive.

**Function**

The valve can be controlled to any intermediate position using an electric drive. When the valve spindle is pulled out, A-AB is closed. Can be used as a control valve with valve actuator AVM 105/115 (S) or valve actuator with spring return AVF 124/125S as mixing and distribution valve.

**As mixing valve**

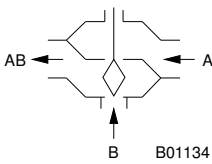

**As distribution valve**

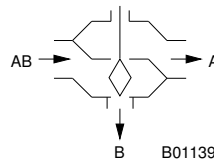

**Description**

These control valves are characterised by being extremely reliable and accurate, and make a considerable contribution to providing environmentally friendly control. They comply with the most demanding requirements such as a quick-closing function, handling differential pressures, controlling media temperatures and providing a shut-off facility – all with a low-noise design.

The valve stem is automatically and firmly connected to the drive shaft. This allows closing against or with the operating pressure to take place. It eliminates plug fluttering in the final position and also prevents cavitation and erosion from occurring at an early stage. Since there is no spring power to counteract the closing of the valve, the full power of the drive is available for the permissible pressure difference. The tightness of the valve is ensured by the seat in the body and the O-ring seal on the plug.

The stuffing box is maintenance-free. This consists of a brass body, 2 O-rings, a scraper ring and a supply of grease. This is silicon-free, i.e. silicon oil must not be used for the stems.

**Engineering and fitting notes**

The valves are combined with the valve drives with or without spring return. The drive is directly attached to the valve and secured using a nut or bolts. The drive is connected to the valve stem automatically. During initial commissioning of the system the drive moves out and the lock closes automatically when it reaches the lower valve seat. The stroke of the valve is also detected by the drive, meaning that no other settings are required. The force on the seat is therefore always consistent and ensures that the leakage rate is minimal. The characteristic curve of the SUT drives can be set to linear or quadratic.

The manual operation facility (accessory) is fitted to the valve like a drive. The connection to the valve shaft takes place automatically when the valve is opened with the knob.

**Installation position**

The final control element can be installed in any position, but a suspended installation position is not recommended. Condensation and dripping water must be prevented from penetrating the drive.

**Using with water**

So that impurities are retained in the water (welding beads, rust particles, etc.) and the spindle seal is not damaged, we recommend installing collecting filters, for example one for each floor or pipe run. Water requirements according to VDI 2035. When using an additive in the water, the compatibility of the materials must be checked with the manufacturer of the medium. The materials table shown below may be used. When glycol is used, we recommend using a concentration of between 20% and 55%.

**Other information regarding hydraulics and noise in systems**

The valves can be used in a low-noise environment. To prevent noise, the pressure differences  $\Delta p_{max}$  listed below should not be exceeded.

The pressure difference  $\Delta p_v$  is the maximum pressure that may act on the valve regardless of the stroke position, in order that the risk of cavitation and erosion is limited. These values are irrespective of the actuator force. Cavitation accelerates wear and causes noises. To prevent cavitation, the pressure differential on the valve should not exceed the value  $\Delta p_{krit}$ :

$$\Delta p_{krit} = (p_1 - p_v) \times 0.5$$

$p_1$  = upstream pressure before the valve (bar)

$p_v$  = steam pressure at operating temperature (bar)

The calculation works with absolute pressure.

For the spring return, the stated  $\Delta p_s$  values are also the permissible differential pressure up to which the actuator can guarantee that the valve is closed in the event of an incident. Because this is a quick-closing function with a “fast” stroke movement (using a spring), this value can exceed  $\Delta p_{max}$ .

**Flow rate chart**

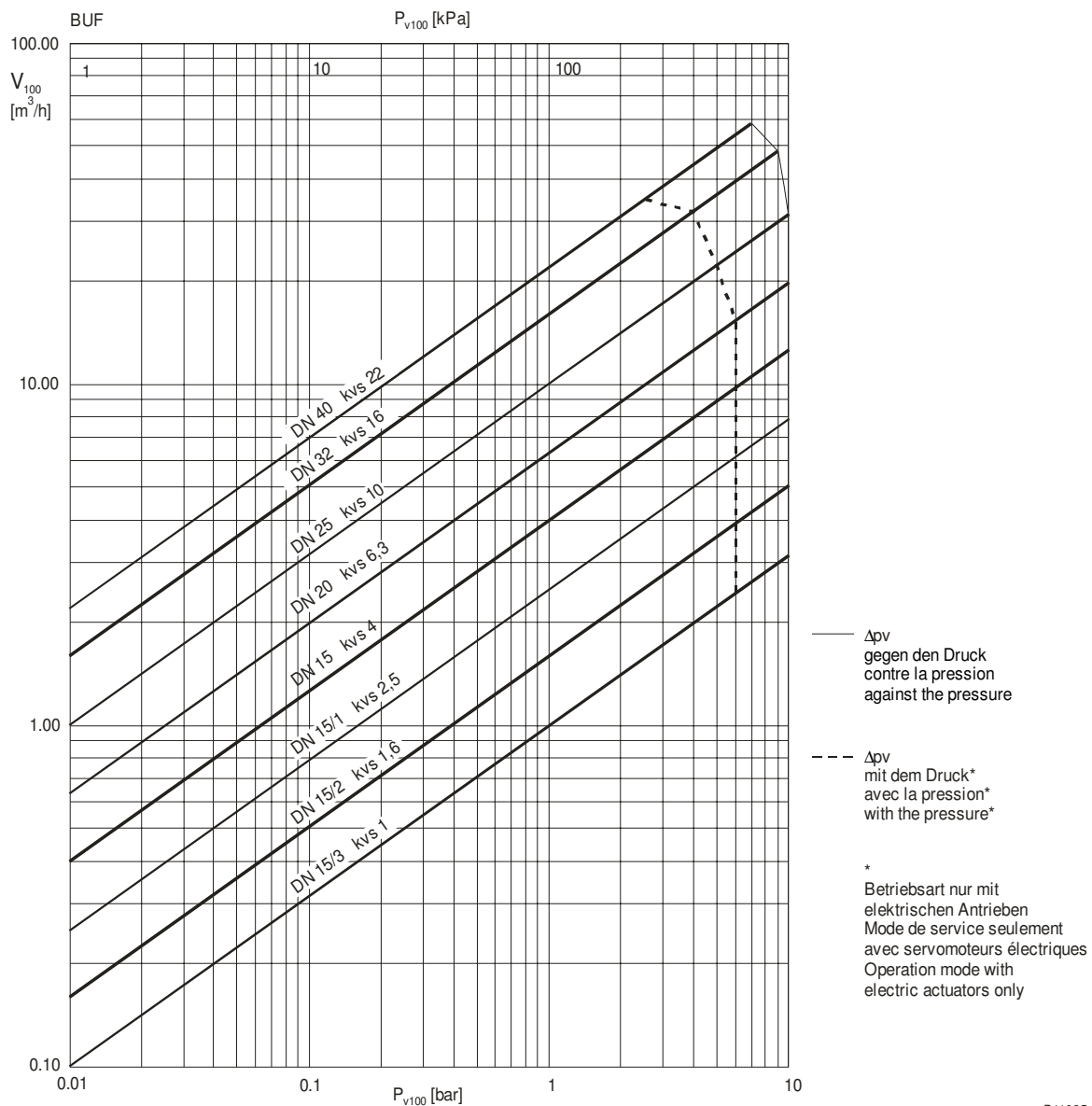

B11035

Type	$\Delta p_v$	
	As mixing valve	As distribution valve
BUF015F230	10	6
BUF015F220	10	6
BUF015F210	10	6
BUF015F200	10	6
BUF020F200	10	6
BUF025F200	10	5
BUF032F200	9	4
BUF040F300	7	2,5

**Additional technical data**

- Pressure and temperature data
- Flow parameters
- SAUTER slide rule for valve sizing
- Technical manual on control units
- Parameters, fitting notes, control, general information
  
- Pressure Equipment Directive, fluid group II
- BUF015 to BUF040: No CE label,

EN 764, EN 1333  
 EN 60534 Seite 3  
 P100013496  
 7 000477 001  
 Applicable EN, DIN,  
 AD, TRD and UVV  
 regulations  
 97/23/EG  
 article 3.3

**Additional version information**

Valve body made of grey cast iron as per EN 1561, code EN-GJL-200 material number EN-JL 1030 with made thread ISO 228/1 classe B, Valve body protected by matt paint RAL 9005 blue.

**Material numbers as per DIN**

	DIN material number	DIN Designation
Valve body	EN-JL 1030	EN-GJL-200
Valve seat	EN-JL 1030	EN-GJL-200
Spindle	1.4305	X 8 Cr Ni S 18-9
Plug	1.4021 / 17 022.5	
Plug seal	EPDM Peroxyde verstärkt	
Stuffing box	CW 617 W	CuZn40Pb2

**Additional details on the definitions of pressure difference**

**$\Delta p_v$ :**

Maximum permissible pressure difference across the valve in any stroke position, limited by the noise level and erosion.

The valve as a traversed element is defined by this parameter specifically in its hydraulic behaviour. By monitoring cavitation, erosion and the noise thus produced, improvements can be achieved in both life expectancy and durability.

**$\Delta p_{max}$ :**

Maximum permissible pressure difference across the valve at which the drive can firmly open and close the valve.

Static pressure and fluidic influences are taken into account. This value helps to maintain a smooth stroke action and the high level of sealing. In doing so, the valve's  $\Delta p_v$  value is never exceeded.

**$\Delta p_s$ :**

Maximum permissible pressure difference across the valve in the event of a malfunction (e.g. power failure, excess temperature or pressure, burst pipe) at which the drive can firmly close the valve and, if necessary, hold the full operating pressure against atmospheric pressure. Since this is a quick-close functions with 'fast' stroke,  $\Delta p_s$  can be larger than  $\Delta p_{max}$  or, respectively,  $\Delta p_v$ . The resultant fluidic disturbances are soon overcome and play a minor role here.

On the three-way valves, the values apply only for the control passage.

**$\Delta p_{stat}$ :**

Line pressure behind the valve. This corresponds largely to the dead pressure when the pump is switched off, e.g. due to the level of liquid in the installation, an increase in pressure via the pressure store, steam pressure etc.

For valves that close with the pressure, the static pressure plus the pump pressure should be used.

**Characteristic for drives with positioners**

On drive AVM 105S or AVM 115S

Equal percentage / linear

On drive AVF 125S

Equal percentage / linear / quadratic

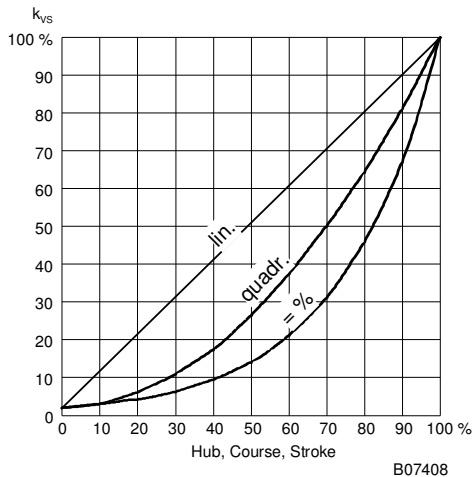

**Dimension drawing**

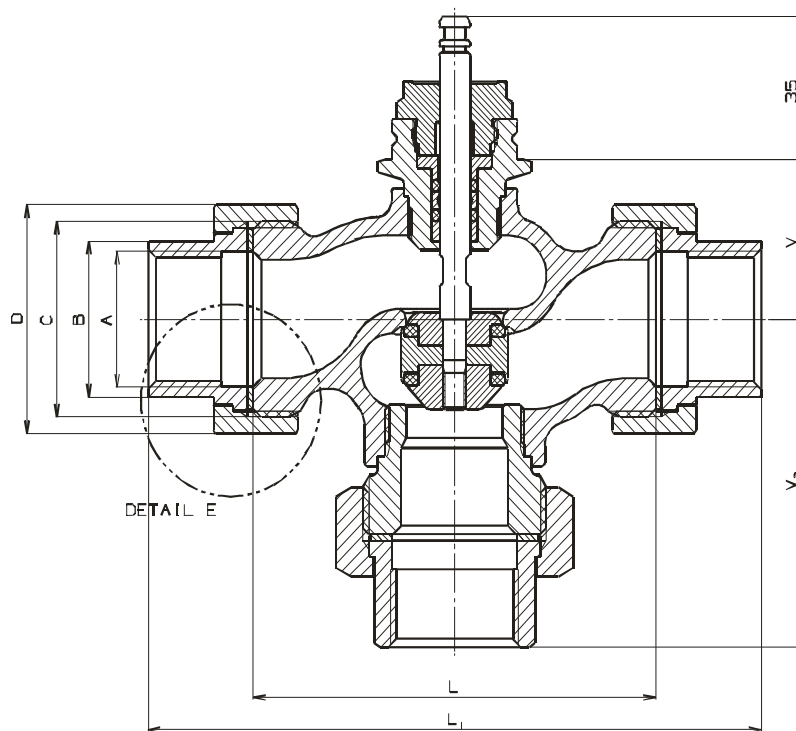

DN	L	L <sub>1</sub>	V	V <sub>3</sub>	A	B	C	D
15	100	146	39	73	1/2	25	1	41
20	100	149	39	74.5	3/4	32	1 1/4	51
25	105	160	39	80	1	38	1 1/2	56
32	130	193	50	96.5	1 1/4	47	2	71
40	140	207	50	103.5	1 1/2	53	2 1/4	76

Combinations

AVF 124/125S

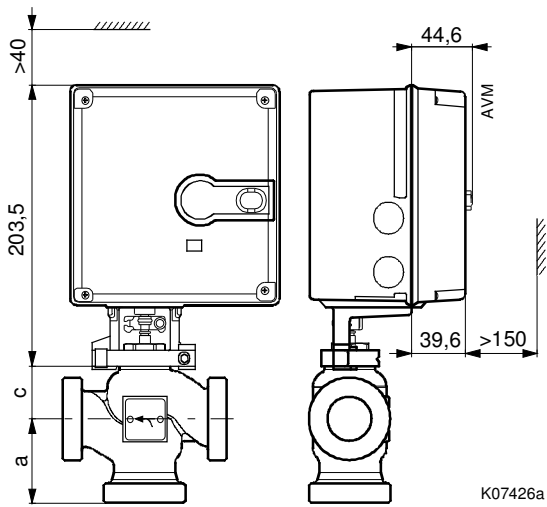

AVM 105 und AVM 115

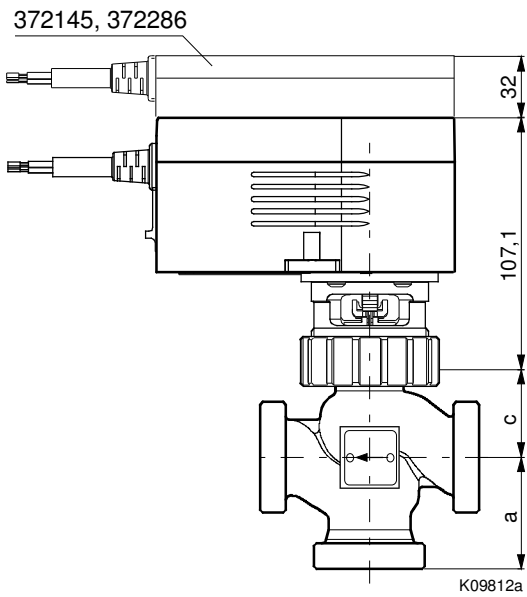

Accessories

